



Faced Duct Wrap Insulation (FDW)



Product Description

AFICO Faced Duct Wrap Insulation is highly efficient, resilient, flexible blanket insulation composed of fine, stable and uniformly textured inorganic glass fibers bonded together by a non-water soluble and fire-retardant thermosetting and heat resistant resin. It is free from coarse fibers and shot due to mineral composition.

Facing

AFICO Faced Duct Wrap Insulation is manufactured in a roll form and subsequently faced on one side by factory laminators, with a suitable vapor retardant Aluminium Foil Reinforced Kraft Paper Laminate (FRK), All Service Jacket (ASJ) and Aluminium Foil Woven Fiberglass Jacket (AWF), or other specific vapor barrier for installation on the exterior of ductwork. The facings have UL fire resistant ratings outdoor or direct bury applications require additional protection from the elements.

Application

AFICO Faced Duct Wrap Insulation is intended for use in commercial, institutional, industrial and residential construction as thermal and acoustical insulation of heating, air conditioning and dual temperature ducts and air handling equipment. The use of Afico Faced Duct Wrap helps prevent condensation when properly applied to air-condition ductwork.

The semi-rigid duct wrap with densities from 16 to 56 kg/m³ (1.0-3.5lb/ft³) are flexible insulation rolls for application over irregularly-shaped surfaces where rigidity properties are desired.

Standard Available Products

Nominal Manufacturing Specifications.
With K and R values.
Check for availability of other dimensions and densities

Apparent Thermal Conductivity ASTM C 518, EN 12667

W/m ·°K or Btu ·in/hr ·ft² ·°F for all product range
"K" or "λ" value at mean temperatures
Data for 10, 24 and 35°C mean temperature

Nominal R Value @24°C mean temperature

Product Type	Density		K Value		R Value / Thickness									
	Kg/m ³	Lb/ft ³	W/m·°K	BTU-in/hr-ft ² ·°F	25 mm	1 in.	38 mm	1 ½ in.	50 mm	2 in.	64 mm	2 ½ in.	75 mm	3 in.
FDW 160	16	1.0	0.037	0.26	0.68	3.78	1.03	5.75	1.35	7.57	1.73	9.69	2.03	11.40
FDW 240	24	1.5	0.034	0.24	0.74	4.10	1.12	6.23	1.47	8.20	1.88	10.50	2.24	12.30
FDW 320	32	2.0	0.033	0.23	0.76	4.37	1.15	6.50	1.52	8.56	1.94	10.95	2.27	12.80
FDW 480	48	3.0	0.031	0.22	0.81	4.47	1.23	6.80	1.61	8.95				
FDW 560	56	3.5	0.031	0.22	0.81	4.69	1.23	7.12	1.61	9.37				

Other thickness available upon request and verification





Faced Duct Wrap Insulation (FDW)

Faced Duct Wrap Insulation (FDW)

Performance & Physical Characteristics

Product Type	Density		Mean Temperature					
	Kg/m ³	Lb/ft ³	10°C	50°F	24°C	75°F	35°C	95°F
FDW								
160	16	1.0	0.034	0.24	0.037	0.26	0.039	0.27
240	24	1.5	0.032	0.22	0.034	0.24	0.036	0.25
320	32	2.0	0.031	0.22	0.033	0.23	0.034	0.24
480	48	3.0	0.030	0.21	0.031	0.22	0.033	0.23
560	56	3.5	0.029	0.20	0.031	0.221	0.032	0.22

Thermal Resistance "R" Value (ASTM C518)

"R" is a measure of the resistance to heat flow of a material of any given thickness. ("R" = m² °K/W or hr-ft²·°F/Btu)

$$R = \frac{T}{K} \quad \text{Where "T" = Thickness}$$

$$\quad \quad \quad \text{Where "K" or "λ" = Thermal Conductivity}$$

Thermal Resistance "U" Value (ASTM C168)

"U" is a measure of how much heat is lost through a given thickness of a particular material. ("U" = W/m² ·°C or Btu/hr ·ft²·°F)

$$U = \frac{1}{Rt} \quad \text{Where "Rt" = Total Thermal Resistance}$$

$$\quad \quad \quad \text{Composed of all elements/layers}$$

U-Values are calculated from the thermal resistances of the parts making up a particular part of the structure. Transmission of heat is opposed in varying amounts dependent on material and surface.

$$U\text{-Value (of building element)} = 1 / (R_{so} + R_{s1} + R_1 + R_{s2} + \dots)$$

Where R_{so} is the fixed external resistance
 R_{si} is the fixed internal resistance
 R₁, R₂ etc are resistivity of all elements within the application including that of cavities within the construction.

Example Calculation:

Layer & Material	Thickness & Conductivity	R Value
R _{so} - Fixed external resistance	-	0.40m ² ·°K/W
R _{si} - Fixed internal resistance	-	0.13m ² ·°K/W
R1 - Fiberglass insulation	0.100 m; 0.035 W/mK	2.85m ² ·°K/W
R2 - Clay bricks	0.105 m; 0.710 W/mK	0.15m ² ·°K/W
R3 - Concrete blocks	0.100 m; 0.018 W/mK	0.55m ² ·°K/W
R4 - Plaster	0.013 m; 0.016 W/mK	0.08m ² ·°K/W
Total		4.16m ² ·°K/W

Therefore the overall wall element U-value = 1/R = 1/4.16 = 0.24W/m²·K



Surface Burning Characteristics (ASTM E 84 , UL 723)

Base glass fiber is non-combustible when tested to ASTM E 84.

Facing	Flame Spread Index	Smoke Developed Index
FRK	≤ 25	≤ 50
ASJ	≤ 25	≤ 50
AWF	≤ 25	≤ 50

Working Temperature Limitations (ASTM C411)

Operating temperature up to 232°C. At excessive temperatures, limited migration of binder may occur in the insulation in contact with the surface. This in no way impairs the performance of the insulation.

Mold Growth (ASTM C1338)

Does not breed or sustain mold, fungus, bacteria or rodents.

Corrosiveness (ASTM C 665)

Chemically inert. Will not cause or accelerate corrosion of steel, stainless steel, copper or aluminum, due to its particular inorganic and mineral composition.

Water Vapor Sorption (ASTM C 1104)

Less than 1% by weight

Odor Emission (ASTM C1304)

Passed, no detectable odor that is objectionable and strong

Alkalinity (ASTM C 871)

pH 9

Specification Compliance

AFICO Faced Duct Wrap Insulation complies with the standard specification requirements of the following specifications:

DCL : ASTM C665 Type I, Type II and Type III with different classes & categories
 ASTM C 553 Type I, Type II and Type III

CE-EN : EN 13162-T1-1121-CPD-BA0137

UL 723 : Classified as FHC 25/50 File no R27731

ASTM C795 : Thermal Insulation for use in contact with Austenitic Stainless Steel tested

SASO : SASO EN 13162
 License # 20240660861

SCS Global : SCS-HPD-09461

Global Green Tag : ARA:DS01:2025:GR

Global Green Tag : ARA:DS01:2024:PH

Emirates GBC : EmiratesGBC

SCS Global : SCS-RC-02810

SCS-IAQ-07373

SCS-EPD-08452

Non-Fibrous (Shot) Content (ASTM C 1335)

Not applicable to glass mineral fiber products.

Fire Properties

B.S. 476 PART 4: Non Combustible

B.S. 476 PART 5: Ignitability

B.S. 476 PART 6: Fire Propagation

B.S. 476 PART 7: Surface Spread of Flame

Class '0' fire rating to the building regulations sections E15

NFPA: 90A and 90B for material specifications only

Note: Need to verify for every product density, thickness and facing combination for the exact compliance

Facing Information (Flexible Vapor Barrier)

ASTM C 1136 Standard specification for Flexible, Low Permeance Vapor Retarders for Thermal Insulation

Vapor Permeability (ASTM E 96 A)

FRK: 0.02 perms

ASJ: 0.02 perms

AWF: 0.00 perms

Product Type	Density		Thickness	
	Kg/m ³	Lb/ft ³	25 mm	50 mm
FDW				
160	16	1.0	0.60	0.85
240	24	1.5	0.65	0.90
320	32	2.0	0.65	0.95
480	48	3.0	0.73	1.00
560	56	3.5	0.75	1.05

Puncture Resistance

FRK: 25 beach units

ASJ: 85 beach units

AWF: 1170 beach units

Acoustical Performance (ASTM C 423)

Standard test Method for Sound Absorption and Sound Absorption coefficients by the Reverberation Room Method, Type A mounting.

Nominal NRC Values

Condensation Control

How to select appropriate thickness for condensation control: to determine thickness to prevent condensation at various ambient temperature and humidity levels based on installed thickness 75% of nominal (out-of-package) thickness, 55 °F air duct internal temperature:

1. Select maximum expected relative humidity (RH) on the lower scale.
2. Move up vertically until that line intersects the expected maximum ambient air temperature.
3. Select the thickness indicated by the intersection point.

Installation Recommendation

AFICO Faced Duct Wrap Insulation products are available in rolls. The desired application length can be easily measured and cut from the full roll. Afico Faced Duct Wrap Insulation can be impaled on pins and adhered with recommended adhesive. When using aluminium alloys pins, pin spacing along a duct should be no greater than 300 mm on centers. Fasteners should be located no less than 75 mm from each edge or corner.

Apply vapor-seal pressure-sensitive aluminium joint sealing tape to joints and protrusions. 75mm wide tape should be used.

Note: Outdoor applications require additional weather protection

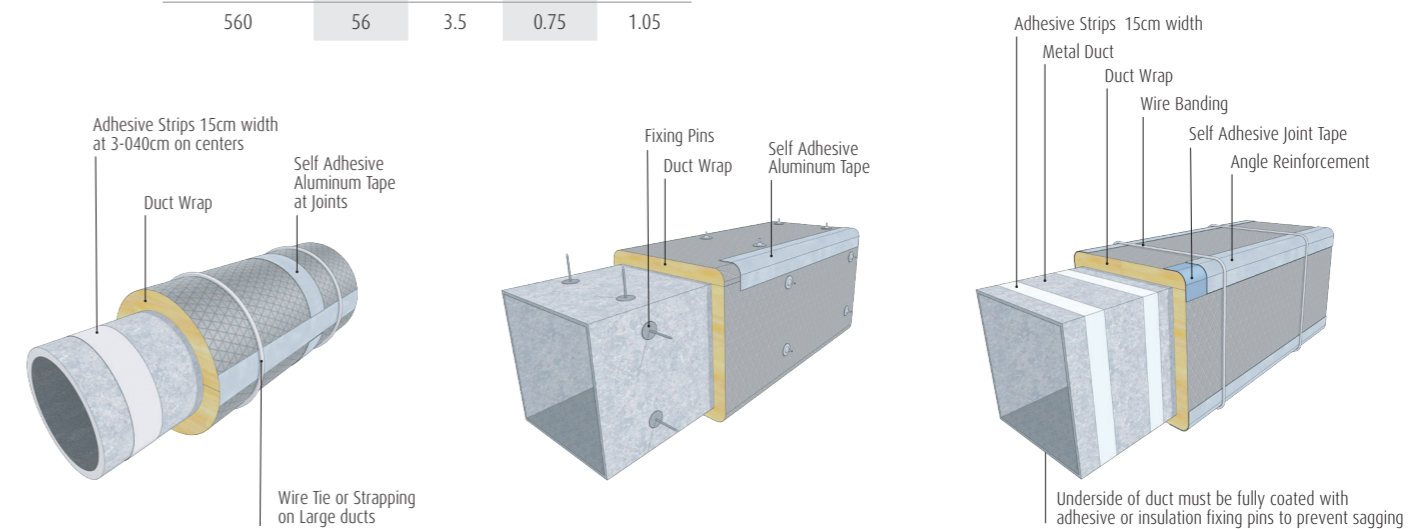



Faced Duct Wrap Insulation (FDW)

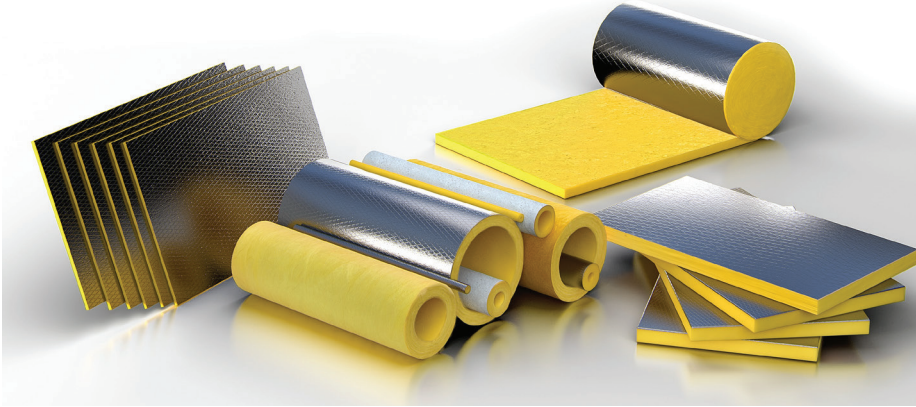

Our Product Range includes

- Cavity Wall Insulation • Blanket Insulation • Duct Liner Board • Duct Liner • Faced Duct Wrap • Quiet Liner
- Thermal Insulating Wool • Pipe Wrap Insulation • Quiet Liner Board • Acoustical Ceiling Panels • Board Insulation
- Roof Deck Board Insulation • Heavy Density Pipe Insulation • HD Series Blanket Insulation
- Pre-engineered Metal Building Insulation • Mechanical Board Insulation

Call us today for more information & professional guidance:

Dammam (H.O. & Factory) : +966 13 331 3333
 Riyadh: +966 11 472 5555
 Jeddah: +966 12 670 0020
 GCC & Int'l Export Office (Dubai) : +971 4 294 1211
 Egypt (Cairo) : +20 100 009 9209
 North Africa (Tunis) : +216 2 053 1000

Please send all email inquiries to info@afico.com.sa



People & Planet Always First

AFICO's products are all energy saving environmentally friendly, use even more recycled materials and contribute to the fight against global warming.

A Subsidiary of



AFICO operates as a subsidiary of Gulf Insulation Group, With Owens Corning serving as its technology partner

Maintenance

No maintenance is required. AFICO Faced Duct Wrap Insulation products have a high resistance to accidental damage from knocks and handling during installation and maintenance. Dimensionally stable under varying conditions of temperature and humidity, rot proof, odorless, non-hygroscopic and will not sustain vermin or fungus due to its inorganic and mineral.

The product will maintain its thermal properties throughout the lifetime of the construction and will not age. AFICO fiberglass is non-toxic and presents no hazard to health.

Storage

To avoid moisture in the building construction, AFICO insulation products stored outside must be kept dry. We recommend AFICO products to be always stored in covered and dry areas. AFICO is not liable for the damage resulting from inadequate utilization, loading and off-loading and mishandling of its products.

Warranty

See manufacturer's General Terms and Conditions of Sale. As AFICO and/or OCF has no control over installation design, installation workmanship, accessory materials, or conditions of application, AFICO and/or OCF does not warrant the performance or results of any installation containing their products. This warranty disclaimer includes all implied warranties, including the warranties or merchantability and fitness for a particular purpose.

Arabian Fiberglass Insulation Company AFICO reserves the right to alter product specifications without prior notice, as part of its policy of continued development and improvement. The installation methods described in this leaflet are not compulsory. The choice of materials and methods of fixing are the decision of the specifier, consultant or contractor. For further information or advice on specification of products, contact your local, sales office.

Availability

Manufactured by Arabian Fiberglass Insulation Company, Ltd. (AFICO), a subsidiary wholly owned by Gulf Insulation Group. AFICO has headquarters and production facilities located in Dammam, Saudi Arabia, operating under license from and utilizing the manufacturing specifications and technology of Owens-Corning Corporation (OCF), Toledo, Ohio, U.S.A.

Marketed throughout Saudi Arabia, the G.C.C. countries, the Middle East, and the Far East, AFICO products are available directly as well as through a vast and reliable network of local distributors.

Special products are manufactured on request.



afico.com.sa